

## DIGITAL AIR COMMAND

### INSTALLATION INSTRUCTIONS

Congratulations on your purchase of a Digital Air Command kit. This kit was designed to provide inflation control of your air helper springs. This kit will be an asset to your vehicle, meeting nearly all of your air supply needs.

Please take a few minutes to read through the instructions to identify the components and learn how to properly install your Digital Air Command kit.

### NOTE:

The Digital Air Command kit can be used with all air helper spring products. If you are installing an air suspension system, do not install the air line tubing to the air springs as stated in the suspension system instruction manual. If you are adding the Digital Air Command kit to an existing air suspension system, you will need to deflate the air springs and remove the air line tubing.

### NOTE ON CONNECTING THE AIR LINE TUBING

Cut the air line tubing as squarely as possible. To connect the air line tubing to the fittings, push the tubing into the fittings as far as possible. If for any reason the tubing must be removed, first release the air pressure from the air helper spring. Push the collar towards the body of the fitting and then pull out the tubing. To reassemble, make sure the tubing is cut squarely and push the tubing back into the fitting.

### TOOLS NEEDED:

Center Punch	3/16" Drill Bit
3/8" Drill	Wire Crimpers
3/8" Wrench	1/2" Wrench
5/8" Wrench	7mm Wrench
Phillips Screwdriver	

### PARTS LIST

DIGITAL GAUGE	9368	1	3/16" FLAT WASHER	14
AIR COMPRESSOR	9283	1	10-32 X 3/4" MACHINE SCREW	1
VALVE BLOCK	9318	1	10-32 X 1" MACHINE SCREW	4
PRESSURE SENSOR	9054	1	10-32 X 1 1/2" MACHINE SCREW	2
EXHAUST VALVE	9278	1	10-32 NYLOCKNUT	7
WIRE HARNESS	9370	1	VELCRO TABS	4
AIR LINE	0938	1	NYLONTIE	15
MALE FITTING	3055	4		

## Air Line & Wiring Diagram

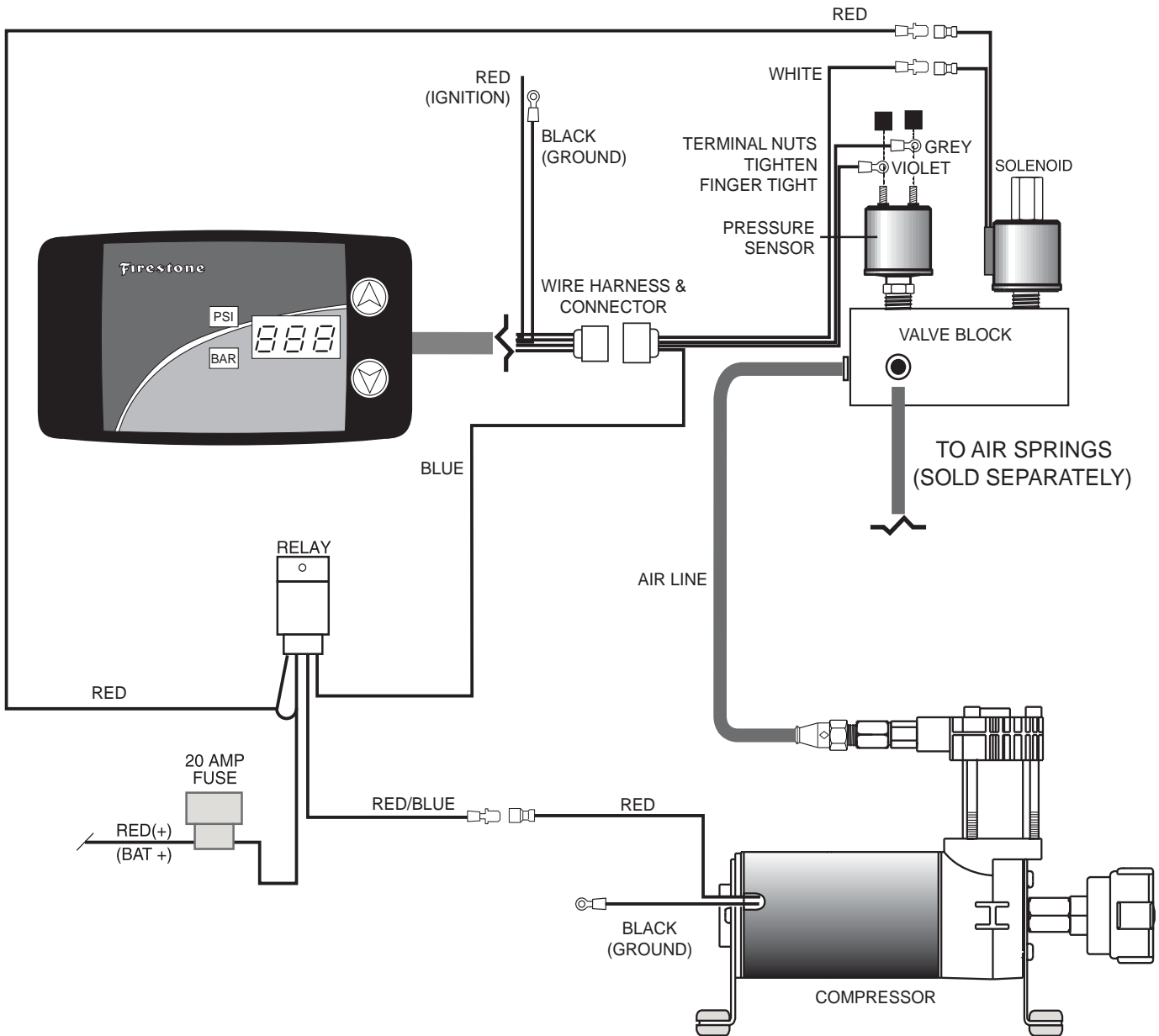

### System Operation

Push the up or down button to set the air springs to the desired pressure. After the button is released, the system will inflate or deflate to the set pressure. The system may make periodic adjustments to maintain the set pressure. The system will not deflate below 5 PSI and will not inflate past 120 PSI. If the system pressure is above or below these levels, a warning will be displayed. To change the display values from PSI to BAR, or BAR to PSI, press and hold both the up and down buttons at the same time.

Figure "A"

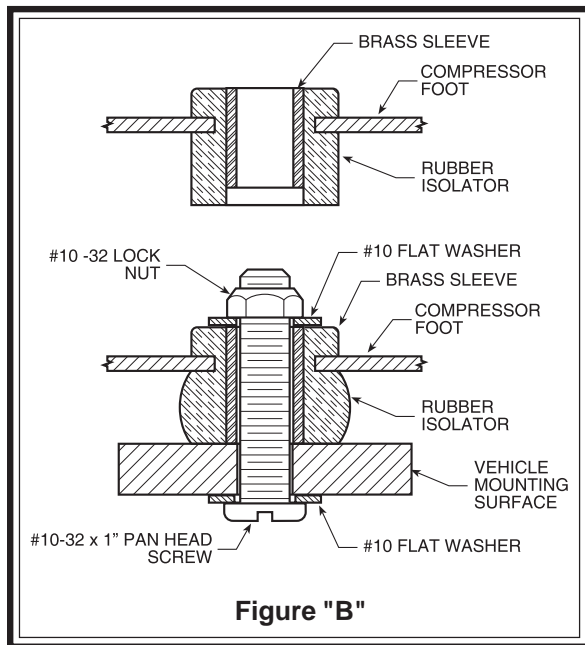

### STEP 1 – MOUNT THE COMPRESSOR

Begin by removing the negative battery cable. Select a convenient location to mount the compressor. This location should provide ample air flow and be protected from airborne debris and moisture. The mounting surface should be rigid to support the compressor. The compressor is oil-less and can be mounted in any orientation necessary for installation. Make sure that the wire harness will reach from the compressor to the anticipated location of the digital gauge. Install a male fitting into the threaded output port on the compressor head, *see Figure "A"*. Tighten the fitting sufficiently to engage at least two threads with the pre-applied thread sealant. **DO NOT OVER TIGHTEN THE FITTING.** Mark the four compressor mounting holes using the compressor as a template and a center punch, then drill four 3/16" holes. Mount the compressor using the supplied 10-32 x 1" machine screw, 10-32 nylock nuts and 3/16" washers. *See Figure "B"*. Attach the black wire from the compressor to a convenient ground source on the vehicle.

### STEP 2 – MOUNT THE MANIFOLD BLOCK

Select the valve block from your kit and install the exhaust valve into the top of the manifold block. Tighten the valve sufficiently to engage at least two threads with the pre-applied thread sealant. Install the pressure sensor into the top of the valve block next to the exhaust valve. Install the three male fittings into the sides of the valve block. Tighten the fittings sufficiently to engage at least two threads with the pre-applied thread sealant. *See Figure "A"*. Select a convenient location to mount the valve block next to the compressor. Mark the two mounting holes using the valve block as a template and a center punch, then drill two 3/16" holes. Mount the valve block using the supplied 10-32 x 1-1/2" machine screws and 10-32 nylock nuts.

### STEP 3 – WIRE HARNESS FROM THE COMPRESSOR AND VALVE BLOCK

Insert the red/blue wire from the relay with the male spade terminal into the female spade terminal on the red wire from the compressor. Insert the white wire from the wire harness with the male spade terminal into the female spade terminal on the exhaust valve. Insert the red wire from the wire harness with the male spade terminal into the female spade terminal on the second female spade terminal on the exhaust valve. The remaining red wire in the wire harness with the fuse will be connected to a 12 Volt, 20 Amp positive power source. *See Figure "A"*. Attach the violet and grey wires with ring terminals from the wiring harness to the studs on the pressure sensor. Tighten the nuts on the pressure sensor terminals figure tight. **DO NOT OVERTIGHTEN THE TERMINAL NUTS.** *See Figure "A"*.

### STEP 4 – MOUNT THE DIGITAL GAUGE

The digital gauge panel must be mounted in a dry protected location with a flat mounting surface. Install the four velcro tabs on the back of the gauge and then firmly place the digital gauge panel onto the mounting location. Optionally, there are 6/32" mounting holes on the back of the gauge for permanent mounting.

### STEP 5 – WIRE HARNESS FOR THE DIGITAL GAUGE PANEL

Connect the black wire from the gauge wire harness to suitable ground and the red wire to a 12V(+) ignition activated power source. Route the wire harness from the compressor and manifold block to the gauge. Use the nylon ties provided to secure the wire harness to the vehicle. Route the wire harness to avoid direct heat from the exhaust system and away from any sharp edges. Insert the male connector into the female connector until a clicking noise is heard. *See Figure "A"*.

## **STEP 6 – ROUTE THE AIR LINE**

Cut a section of air line tubing that will reach from the compressor to the valve block. Cut the air line tubing as squarely as possible and insert the tubing into the male fitting on the compressor and then into the fitting on the valve block marked **IN**. Cut a section of air line tubing that will reach from the valve block to one of the air springs. Cut the air line tubing as squarely as possible and insert the tubing into the fitting on the valve block and then insert the other end into the air spring. Use the nylon ties provided to secure the air line tubing to the vehicle. Route the tubing to avoid direct heat from the exhaust system and away from any sharp edges. Repeat this last step on the other air spring and remaining fitting.

## **STEP 7 – CHECK THE SYSTEM**

With the Dual Digital Air Command kit and the air springs installed you are ready to test the system. Re-attach the negative battery cable. Turn on the vehicle's ignition. Push and hold the up button to inflate the air springs. The gauge will display how much air pressure is in the system. Inflate the air springs to 70 psi or the max air spring pressure, whichever is less, and check the fittings for air leaks with a solution of soap and water. If a leak is detected at a tubing connection, check to make sure that the tube is cut as squarely as possible and that it is pushed completely into the fitting. The tubing can easily be removed from the fitting by first releasing the pressure from the air spring, then by pushing the collar towards the body of the fitting and holding, then pulling the tube out.

## **Trouble Shooting the System**

*Display powers up but it will not inflate or deflate* – The red power wire in the wire harness is not connected to the battery.

*The display blinks “Hi” & “150” repeatedly and will not inflate or deflate* – One of the wires for the pressure sender is not connected or making contact.

